



12V-100Ah/12V-230Ah LITHIUM BATTERY



Important Safety Instructions



Please save these instructions

This manual contains important installation, operation, and maintenance instructions for the Smart Lithium Iron Phosphate Battery. Please observe these instructions and keep them located near the battery for further reference. The following symbols are used throughout the manual to indicate potentially dangerous conditions or important safety information.

WARNING

Indicates a potentially dangerous condition. Extreme caution when performing this task.

CAUTION

Indicates a critical procedure for the safe and proper installation and operation of the battery.

NOTE

- Indicates a procedure or function that is important to the safe and proper installation and operation of the battery.
- After receiving the battery, first install the APP, turn on the charge and discharge MOS. Otherwise, the battery cannot be discharged or charged, ► (Bluetooth Operation Instructions)

Disclaimer

The manufacturer accepts no liability for any damage caused by

- Force majeure including fire, typhoon, flood, earthquake, war, and terrorism.
- Intentional or accidental misuse, abuse, neglect or improper maintenance, and use under abnormal conditions.
- Improper installation, operation, and malfunction of a peripheral device.
- Contamination with hazardous substances, diseases, vermin, or radiation
- Alterations to the product without express written consent from the manufacturer

General Safety Information

WARNING

- Keep the battery away from water, heat sources, sparks, and hazardous chemicals.
- DO NOT puncture, drop, crush, burn, penetrate, shake, or strike the battery.
- DO NOT open, dismantle, or modify the battery.
- DO NOT touch any terminals or connectors
- DO NOT touch the exposed electrolyte or powder if the battery casing is damaged.
- Uncovered electrolyte or powder that has contacted the skin or eyes **MUST** be flushed out with plenty of clean water immediately. Seek medical attention afterwards.
- Please make sure any battery charger or charge controller has been disconnected before working on the battery.
- DO NOT connect or disconnect the battery terminals without first disconnecting loads.

CAUTION

- DO NOT place tools on top of the battery
- Please keep the battery out of the reach of young children.
- Please wear proper protective equipment when working on the battery.
- Please use insulated tools when working on battery.
- DO NOT wear jewelry or other metal objects when working on or around the battery.
- Please ensure adequate and secure mounting of the battery.
- Please use suitable handling equipment for safe transportation of the battery.
- DO NOT dispose of the battery as household waste. Please use recycling channels in accordance with local, state, and federal regulations.

Please read this manual prior to installation and use

Thank you for investing in a Li-Cube series battery. This manual provides important information on how to install, operate, care for your Li-Cube investment . If you have purchased with us before, you will find this manual useful as a reference tool. If this is your first purchase with Li-Cube , this manual can serve as an educational tool on how to properly use and care for your investment.

If you have a heat-enabled model, please refer to the additional Heat-Enable Instruction manual prior to use and installation.

Contents

Product Overview.....	04
What is in the Box ?	05
What Do I Need for Installation ?	05
Connecting Load Specified Cables to the Batteries	05
Important Safety	07
Properly Charging the Batteries	08
Connecting the Batteries in Parallel	08
Bluetooth Operation Instructions	10
How does the BMS Protect the Batteries	13
Voltage vs. Capacity	14
How to Properly Size Cables for System Install	14
How to Properly Store Batteries.....	15
How to Maintain the Batteries	15
How to Properly Recycle and Dispose of the Batteries	15
Warranty	15
Exemption from Liability.....	15
Specifications.....	16



CONFORMS TO
UN38.3 
Conforms to UL STD 62133-2
Certified to CSA STD C22.2# 62133-2
Conforms to UL STD 2054



Product Overview

Identification of Parts



Dimensions

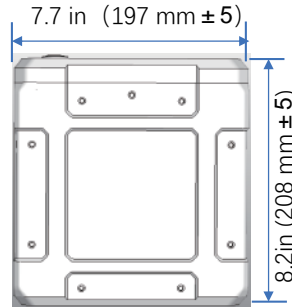
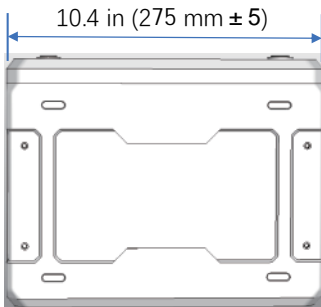

12V-100AH

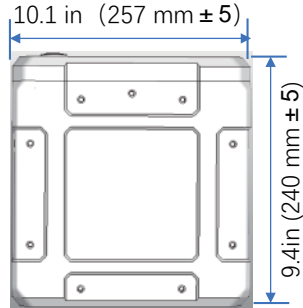
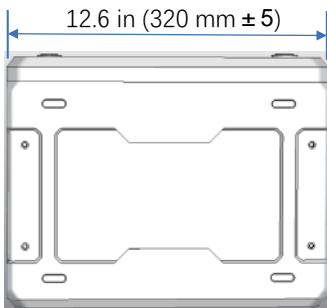

12V-230AH

What is in the Box ?

Included with your purchase is:

	12V-100AH	12V-230AH
Dimensions (L x W x H)	10.4" x 7.7" x 8.2" (L264x197x208mm)	12.6" x 6.86" x 8.95" (L320x257x240mm)
Weight	22 lbs (10Kg)	48.5lbs (22Kg)
Operating Temp Range	-40 F ~ 140 F (-40 C ~+55 C)	

- Water Resistant and Sealed (Batteries should not be submerged in water)
- Built-in BMS (Battery Management System)
- Made with square Cells
- Comes with standard flag style terminal posts with a M8 hole to accommodate either a M8 bolt

What Do I Need for Installation?

If your system is already set up and ready for battery installation, you will need a torque wrench to properly tighten the M8 bolt. This is **EQUIRED** to make sure that you torque to the specification of 14N. , otherwise you may cause system failures and damage.

Connecting Load Specified Cables to the Batteries

1. Identify the positive and negative terminals. These are labeled and color-coded red for positive (+), black for negative (-)



Positive (+)



Negative (-)

2. Determine which finishing hardware set you will use. Verify that your bolt can fully seat into the nylok insert of the nut. If multiple lugs are used, longer bolts may be required for the bolt to fully seat into the nylok insert of the nut.

3. Connect your cable lugs to your battery terminal with the previously identified finishing hardware set. Make sure to connect your positive load specified cable lug to the positive terminal and the negative load specified cable lug to the negative terminal. The proper order to connect to your terminal with a finishing kit is shown in Fig. 1.



Fig. 1

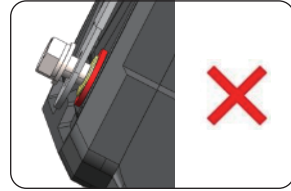

Fig. 2

4. When connecting to your battery terminals, DO NOT finger tighten. Use a torque wrench to tighten the hardware to 14N as specified N . Failure to adequately secure connections can result in severe damage and will void your warranty.

Fig. 2 below demonstrates proper and improper connections.

Connection Between Base Fixing Parts and Battery PACK

Base (L-Type) fixing parts and battery PACK locking method:

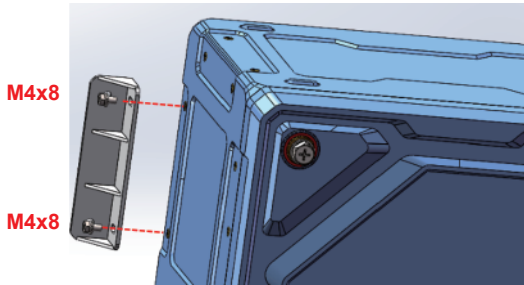

Connect the Fixing Parts to the Battery PACK Connection

Connecting fixed components and battery PACK locking method :

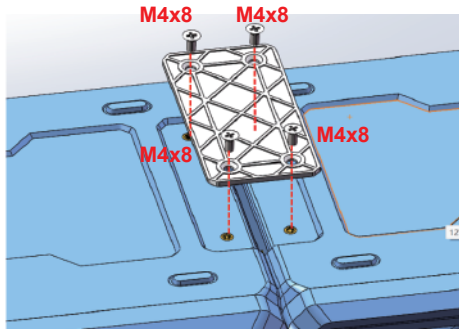

Important Safety

While LiFePO₄ batteries are inherently safe, as with all batteries, energy storage devices, and electrical equipment, safety and electrical hazards do exist. Failure to follow these safety instructions may result in electrical shock, injury, or death, or may damage the battery or other equipment or property.

Installation:

- The battery should be installed according to national and local codes.
- Install the battery only in locations approved by local building codes.
- Do not short the battery terminals.
- Do not install the battery if there are any signs of physical damage.
- Do not install the battery in a location that may be flooded.
- Please do not install in areas with fire sources or high temperatures .
- Place in a cool location .

Operation:

- Use only approved battery chargers for charging the battery.
- Do not disassemble the battery.

Emergency handling :

- Disconnect the battery from the system.
- Wear a respirator, eye protection, and rubber gloves where appropriate .
- Use carbon dioxide extinguisher or foam extinguisher.
- Dispose of as per local regulations.



WARNING



- Do not short battery terminal.
- Do not reverse polarity.
- Do not pierce battery casing.
- Do not attempt to disassemble.
- Do not drop or mishandle.
- Do not immerse in water.
- Do not operate with loose connections.
- Do not operate battery in series or in parallel with any other type of battery.
- Do not connect more than six batteries in series.
- Do not operate using cables that cannot accommodate the maximum current that can be delivered by the batteries (Please contact technical support to verify that you are using appropriate cables and contacts.)

Properly Charging the Batteries

To properly charge your Li-Cube , you will want to verify that any charging component in your system is capable of being programmed for the following specifications. Charging components can include, but are not limited to converters, inverter chargers, solar charge controllers, DC to DC chargers, etc.

- Charging voltage range : 14.2V – 14.6V
- Charge mode : CC-CV
- Equalization start voltage : 14.4V
- When battery capacity : 50%
- Battery Charge Temperature Range: 32°F (0°C) – 131°F (55°C)
- Battery Discharge Temperature Range: -4°F (-20°C) – 140°F (60°C)

Connecting the Batteries in Parallel

Why Connect in Parallel?

Multiple 12V/100Ah batteries can be connected in parallel to increase the system's capacity and current. When batteries are connected in parallel, the voltage of the system does not change, but the capacity and current are accumulated. For example, two parallel 12V/100Ah batteries (as shown in Figure 3) form a 12V 200Ah battery pack that can continuously provide 200A current.

How to Make a Parallel Connection

1. Identify the positive and negative terminals. These are labeled and color-coded red for positive (+), black for negative (-) .
2. Determine the appropriate finishing hardware set you will use. Verify that your bolt can fully seat into the nylok insert of the nut. If multiple lugs are used, longer bolts may be required for the bolt to fully seat into the nylok insert of the nut.
3. Make the proper Copper guide plate connections to the positive of the first battery. As shown in the following figure .

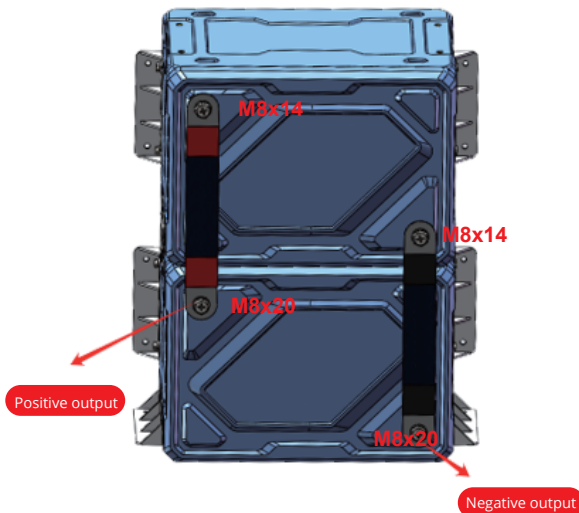

4. When connecting to your battery terminals, Use first finger preliminary lock up , then use torque wrench to torque your hardware to the specification of 14N. Failure to adequately secure connections can result in severe damage and will void your warranty .
5. Connect the other end of your positive cable to the positive terminal of the other battery you are connecting to. Repeat step 4.
6. Repeat steps 3-5 for the negative connections.
7. Repeat steps 3-6 for additional batteries in the system, as shown in the following figure.



Positive (+)



Negative (-)

8. Assemble method of Battery pack :
Parallel:

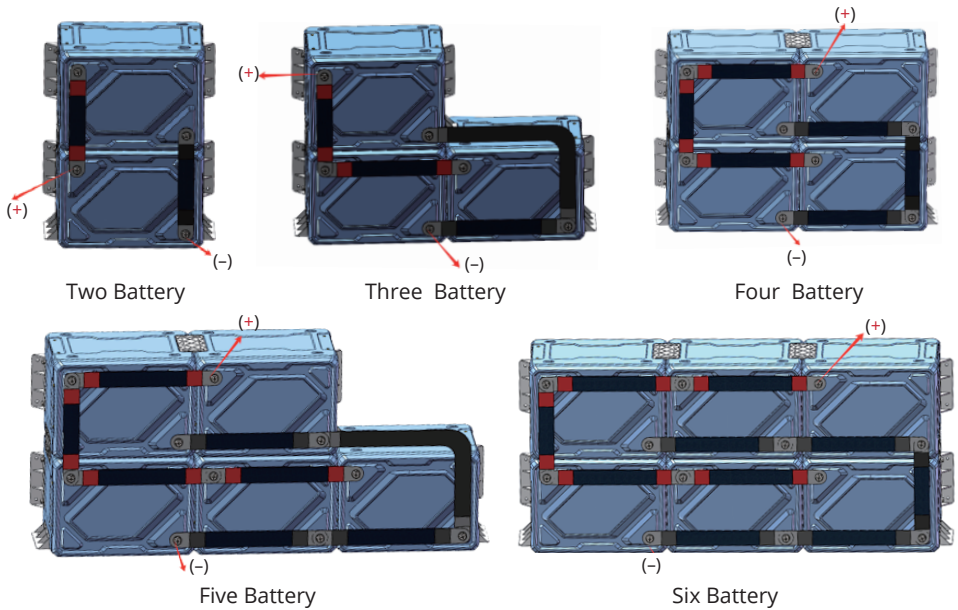

Series :

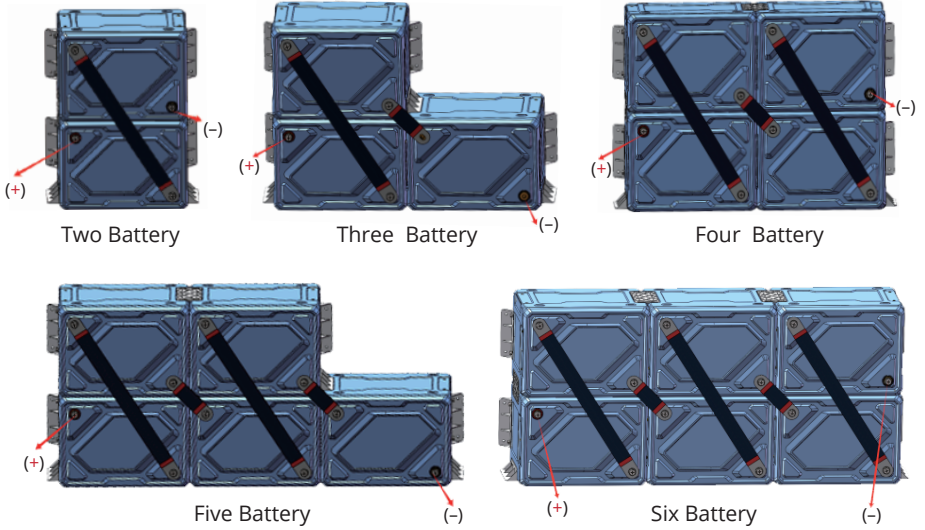

Bluetooth Operation Instructions

NOTE

After receiving the battery, first install the APP, turn on the charge and discharge MOS, otherwise, the battery cannot be discharged and charged

App installation

For For APP installation on an Apple phone, please go to the Apple App Store and search for 'Li-Cube'.
Android phone, Please go to the Google play search for "Li-Cube" please scan the following image.



Program Name : **Li-Cube**

Click on the image on your phone to enter and select the battery pack number you want to connect .

Each battery has Unique ID code on the battery

Click on the APP icon to execute the program, Two Schemes

A: Main screen , APP scans the ID Code QR code on the battery

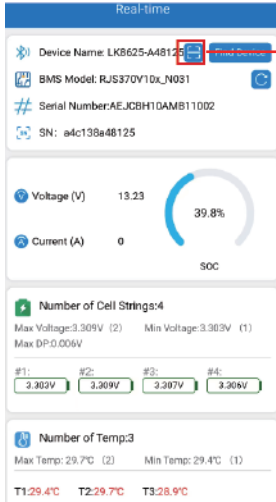

B:Click on 'Find Device' to search for battery PACK Bluetooth battery ID code click " Connected " to enter the connection

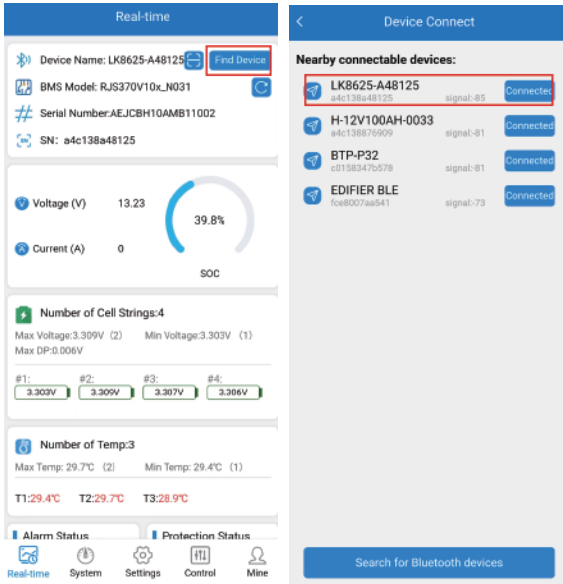

Turn on/off to charge and discharge MOS: (Must perform this operation before using the battery) Click on 'Control'.

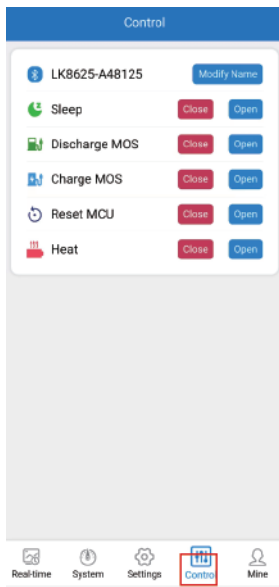

Click on 'system' to view the battery pack status and control. Charging and discharging control and heating control.

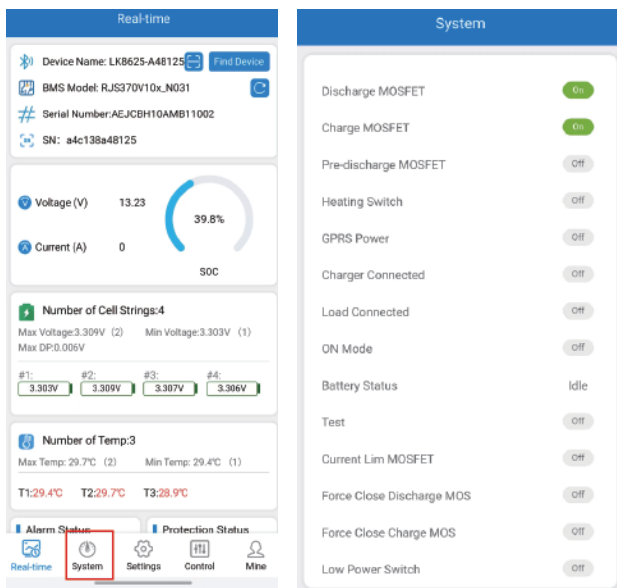

How Does the BMS Protect the Batteries?

All Batteries come with a built-in battery management system (BMS) that protects the cells from many strenuous circumstances to protect the life cycles of the cells and your electrical system from potential damage.

High Voltage Disconnect (> 14.6V)

If an individual cell voltage exceeds a prescribed threshold during charging, the BMS will prevent a charge current from continuing. Discharge is always allowed under this condition. If the batteries have not been balanced for a long time, high voltage disconnect could occur at a lower voltage. The batteries will rebalance after several full charges.

Low-Voltage Disconnect (< 10.0V)

If an individual cell falls below a prescribed threshold during discharge, the BMS will prevent further discharge. Although the battery is in "low-voltage disconnect" mode, it will still allow a charging current.

NOTE: Many chargers must detect a voltage over 10V to send a charge to the battery. Please be aware that some chargers may not sense a battery in low-voltage disconnect and you may need to jump it with a 12V source to "wake up" the battery. You should jump your battery within 24hrs of entering low-voltage disconnect otherwise you risk damaging your battery and voiding the warranty.

High Temperature Charging and Discharging

The BMS will not allow a charging current if the internal temperature of the battery has reached 131°F (55°C). If the internal temperature of the battery has reached 140°F (60°C), the BMS will not allow a discharging current.

Low Temperature Charging and Discharging

The BMS will not allow a charging current under -4°F (-20°C) Discharge down to -40°F (-40°C).

NOTE: The 12/100Ah or 12V/230AH has an operating temperature range of -40°F (-40°C) to 131°F (55°C).

High Current Discharge Surges

The BMS will not allow a current that exceeds 100 /200(+/- 5%) Amps for more than 30s, or anything larger for 0.5s. After a high current disconnection, the battery will automatically reconnect after 5 seconds.

Short Current Discharge Surges Our BMS has built-in short circuit protection. If the short circuit protection is tripped, the BMS will shut the battery down and will remain disconnected until you remove the battery cables. While the battery cables are disconnected, we suggest taking the voltage of the battery with a voltmeter. If it reads above 10V, reconnect the battery cables. If you are unsuccessful at obtaining a voltage reading above 10V, please give our Li-Cube technical support support team a call.

Balancing of Cells

A passive balancing process is activated by the BMS at the top of each charge cycle when the battery voltage exceeds around 14.2V. This ensures that all the cells remain at the same state of charge, improving pack longevity and performance.

Voltage vs. Capacity

Voltage vs. Capacity

For a Single Battery

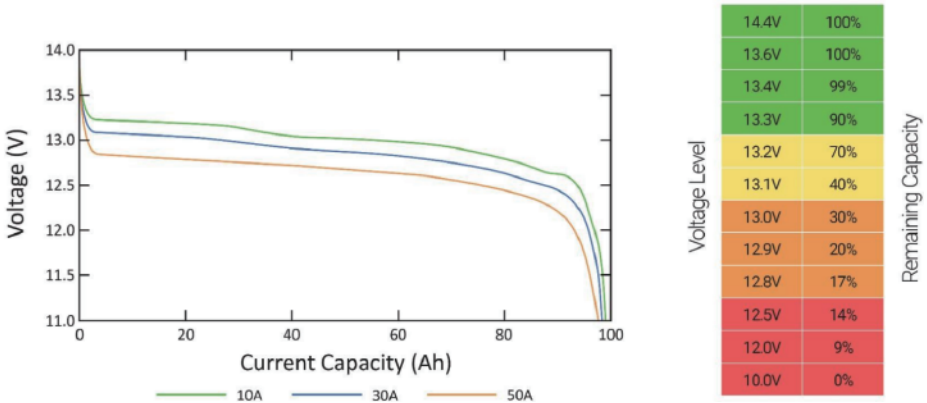

How to Properly Size Cables for System Install

When considering cable sizing there are a few factors to consider. First, what is the size of the load you are powering with the battery bank? Second, how far away from the battery is the load? You can do voltage drop calculations to see if you need to step up your cable size. Fig. 5 is a chart to use for reference. Do keep in mind that cables are only capable of carrying a certain amperage and you should verify the specifications of your cable and the power draws before implementing them into your system to avoid potential failures and damage.

CURRENT (A)	0-5	5-10	10-15	15-20	20-25	25-30	30-40	40-50	50-60	60-70	70-80	80-90	90-100	100-120	120-150	150-200
	16 AWG	16 AWG	14 AWG	12 AWG	10 AWG	8 AWG	6 AWG	4 AWG	4 AWG	4 AWG	4 AWG	2 AWG	2 AWG	2 AWG	2 AWG	2 AWG
	16 AWG	16 AWG	14 AWG	12 AWG	10 AWG	8 AWG	6 AWG	4 AWG	4 AWG	2 AWG	2 AWG	1/0 AWG	1/0 AWG	2/0 AWG	4/0 AWG	4/0 AWG
	16 AWG	16 AWG	14 AWG	12 AWG	10 AWG	8 AWG	6 AWG	4 AWG	4 AWG	2 AWG	2 AWG	1/0 AWG	1/0 AWG	2/0 AWG	4/0 AWG	4/0 AWG
	14 AWG	12 AWG	10 AWG	8 AWG	6 AWG	6 AWG	4 AWG	4 AWG	2 AWG	2 AWG	2 AWG	1/0 AWG	1/0 AWG	2/0 AWG	4/0 AWG	4/0 AWG
	12 AWG	10 AWG	10 AWG	8 AWG	6 AWG	6 AWG	4 AWG	4 AWG	2 AWG	2 AWG	2 AWG	1/0 AWG	1/0 AWG	2/0 AWG	4/0 AWG	4/0 AWG
	10 AWG	10 AWG	10 AWG	8 AWG	6 AWG	6 AWG	4 AWG	4 AWG	2 AWG	2 AWG	2 AWG	1/0 AWG	1/0 AWG	2/0 AWG	4/0 AWG	4/0 AWG
	8 AWG	8 AWG	8 AWG	6 AWG	6 AWG	6 AWG	4 AWG	4 AWG	2 AWG	2 AWG	2 AWG	1/0 AWG	1/0 AWG	2/0 AWG	4/0 AWG	4/0 AWG
	8 AWG	8 AWG	6 AWG	6 AWG	6 AWG	4 AWG	4 AWG	4 AWG	2 AWG	2 AWG	2 AWG	1/0 AWG	1/0 AWG	2/0 AWG	4/0 AWG	4/0 AWG
	6 AWG	6 AWG	6 AWG	6 AWG	4 AWG	4 AWG	4 AWG	4 AWG	2 AWG	2 AWG	2 AWG	1/0 AWG	1/0 AWG	2/0 AWG	4/0 AWG	4/0 AWG
	6 AWG	6 AWG	4 AWG	4 AWG	4 AWG	4 AWG	2 AWG	2 AWG	2 AWG	2 AWG	2 AWG	1/0 AWG	1/0 AWG	2/0 AWG	4/0 AWG	4/0 AWG
	4 AWG	4 AWG	4 AWG	4 AWG	4 AWG	4 AWG	2 AWG	2 AWG	2 AWG	2 AWG	2 AWG	1/0 AWG	1/0 AWG	2/0 AWG	4/0 AWG	4/0 AWG
	4 AWG	4 AWG	4 AWG	2 AWG	2 AWG	2 AWG	2 AWG	2 AWG	2 AWG	2 AWG	2 AWG	1/0 AWG	1/0 AWG	2/0 AWG	4/0 AWG	4/0 AWG
	2 AWG	2 AWG	2 AWG	2 AWG	2 AWG	2 AWG	2 AWG	2 AWG	2 AWG	2 AWG	2 AWG	1/0 AWG	1/0 AWG	2/0 AWG	4/0 AWG	4/0 AWG
	2 AWG	2 AWG	2 AWG	2 AWG	2 AWG	2 AWG	2 AWG	2 AWG	2 AWG	2 AWG	2 AWG	1/0 AWG	1/0 AWG	2/0 AWG	4/0 AWG	4/0 AWG
	2 AWG	2 AWG	2 AWG	2 AWG	2 AWG	2 AWG	2 AWG	2 AWG	2 AWG	2 AWG	2 AWG	1/0 AWG	1/0 AWG	2/0 AWG	4/0 AWG	4/0 AWG
	2 AWG	2 AWG	2 AWG	2 AWG	2 AWG	2 AWG	2 AWG	2 AWG	2 AWG	2 AWG	2 AWG	1/0 AWG	1/0 AWG	2/0 AWG	4/0 AWG	4/0 AWG
	2 AWG	2 AWG	2 AWG	2 AWG	2 AWG	2 AWG	2 AWG	2 AWG	2 AWG	2 AWG	2 AWG	1/0 AWG	1/0 AWG	2/0 AWG	4/0 AWG	4/0 AWG
	2 AWG	2 AWG	2 AWG	2 AWG	2 AWG	2 AWG	2 AWG	2 AWG	2 AWG	2 AWG	2 AWG	1/0 AWG	1/0 AWG	2/0 AWG	4/0 AWG	4/0 AWG
	2 AWG	2 AWG	2 AWG	2 AWG	2 AWG	2 AWG	2 AWG	2 AWG	2 AWG	2 AWG	2 AWG	1/0 AWG	1/0 AWG	2/0 AWG	4/0 AWG	4/0 AWG
	2 AWG	2 AWG	2 AWG	2 AWG	2 AWG	2 AWG	2 AWG	2 AWG	2 AWG	2 AWG	2 AWG	1/0 AWG	1/0 AWG	2/0 AWG	4/0 AWG	4/0 AWG
	2 AWG	2 AWG	2 AWG	2 AWG	2 AWG	2 AWG	2 AWG	2 AWG	2 AWG	2 AWG	2 AWG	1/0 AWG	1/0 AWG	2/0 AWG	4/0 AWG	4/0 AWG
	2 AWG	2 AWG	2 AWG	2 AWG	2 AWG	2 AWG	2 AWG	2 AWG	2 AWG	2 AWG	2 AWG	1/0 AWG	1/0 AWG	2/0 AWG	4/0 AWG	4/0 AWG
	2 AWG	2 AWG	2 AWG	2 AWG	2 AWG	2 AWG	2 AWG	2 AWG	2 AWG	2 AWG	2 AWG	1/0 AWG	1/0 AWG	2/0 AWG	4/0 AWG	4/0 AWG
	2 AWG	2 AWG	2 AWG	2 AWG	2 AWG	2 AWG	2 AWG	2 AWG	2 AWG	2 AWG	2 AWG	1/0 AWG	1/0 AWG	2/0 AWG	4/0 AWG	4/0 AWG
	2 AWG	2 AWG	2 AWG	2 AWG	2 AWG	2 AWG	2 AWG	2 AWG	2 AWG	2 AWG	2 AWG	1/0 AWG	1/0 AWG	2/0 AWG	4/0 AWG	4/0 AWG
	2 AWG	2 AWG	2 AWG	2 AWG	2 AWG	2 AWG	2 AWG	2 AWG	2 AWG	2 AWG	2 AWG	1/0 AWG	1/0 AWG	2/0 AWG	4/0 AWG	4/0 AWG
	2 AWG	2 AWG	2 AWG	2 AWG	2 AWG	2 AWG	2 AWG	2 AWG	2 AWG	2 AWG	2 AWG	1/0 AWG	1/0 AWG	2/0 AWG	4/0 AWG	4/0 AWG
	2 AWG	2 AWG	2 AWG	2 AWG	2 AWG	2 AWG	2 AWG	2 AWG	2 AWG	2 AWG	2 AWG	1/0 AWG	1/0 AWG	2/0 AWG	4/0 AWG	4/0 AWG
	2 AWG	2 AWG	2 AWG	2 AWG	2 AWG	2 AWG	2 AWG	2 AWG	2 AWG	2 AWG	2 AWG	1/0 AWG	1/0 AWG	2/0 AWG	4/0 AWG	4/0 AWG
	2 AWG	2 AWG	2 AWG	2 AWG	2 AWG	2 AWG	2 AWG	2 AWG	2 AWG	2 AWG	2 AWG	1/0 AWG	1/0 AWG	2/0 AWG	4/0 AWG	4/0 AWG
	2 AWG	2 AWG	2 AWG	2 AWG	2 AWG	2 AWG	2 AWG	2 AWG	2 AWG	2 AWG	2 AWG	1/0 AWG	1/0 AWG	2/0 AWG	4/0 AWG	4/0 AWG
	2 AWG	2 AWG	2 AWG	2 AWG	2 AWG	2 AWG	2 AWG	2 AWG	2 AWG	2 AWG	2 AWG	1/0 AWG	1/0 AWG	2/0 AWG	4/0 AWG	4/0 AWG
	2 AWG	2 AWG	2 AWG	2 AWG	2 AWG	2 AWG	2 AWG	2 AWG	2 AWG	2 AWG	2 AWG	1/0 AWG	1/0 AWG	2/0 AWG	4/0 AWG	4/0 AWG
	2 AWG	2 AWG	2 AWG	2 AWG	2 AWG	2 AWG	2 AWG	2 AWG	2 AWG	2 AWG	2 AWG	1/0 AWG	1/0 AWG	2/0 AWG	4/0 AWG	4/0 AWG
	2 AWG	2 AWG	2 AWG	2 AWG	2 AWG	2 AWG	2 AWG	2 AWG	2 AWG	2 AWG	2 AWG	1/0 AWG	1/0 AWG	2/0 AWG	4/0 AWG	4/0 AWG
	2 AWG	2 AWG	2 AWG	2 AWG	2 AWG	2 AWG	2 AWG	2 AWG	2 AWG	2 AWG	2 AWG	1/0 AWG	1/0 AWG	2/0 AWG	4/0 AWG	4/0 AWG
	2 AWG	2 AWG	2 AWG	2 AWG	2 AWG	2 AWG	2 AWG	2 AWG	2 AWG	2 AWG	2 AWG	1/0 AWG	1/0 AWG	2/0 AWG	4/0 AWG	4/0 AWG
	2 AWG	2 AWG	2 AWG	2 AWG	2 AWG	2 AWG	2 AWG	2 AWG	2 AWG	2 AWG	2 AWG	1/0 AWG	1/0 AWG	2/0 AWG	4/0 AWG	4/0 AWG
	2 AWG	2 AWG	2 AWG	2 AWG	2 AWG	2 AWG	2 AWG	2 AWG	2 AWG	2 AWG	2 AWG	1/0 AWG	1/0 AWG	2/0 AWG	4/0 AWG	4/0 AWG
	2 AWG	2 AWG	2 AWG	2 AWG	2 AWG	2 AWG	2 AWG	2 AWG	2 AWG	2 AWG	2 AWG	1/0 AWG	1/0 AWG	2/0 AWG	4/0 AWG	4/0 AWG
	2 AWG	2 AWG	2 AWG	2 AWG	2 AWG	2 AWG	2 AWG	2 AWG	2 AWG	2 AWG	2 AWG	1/0 AWG	1/0 AWG	2/0 AWG	4/0 AWG	4/0 AWG
	2 AWG	2 AWG	2 AWG	2 AWG	2 AWG	2 AWG	2 AWG	2 AWG	2 AWG	2 AWG	2 AWG	1/0 AWG	1/0 AWG	2/0 AWG	4/0 AWG	4/0 AWG
	2 AWG	2 AWG	2 AWG	2 AWG	2 AWG	2 AWG	2 AWG	2 AWG	2 AWG	2 AWG	2 AWG	1/0 AWG	1/0 AWG	2/0 AWG	4/0 AWG	4/0 AWG
	2 AWG	2 AWG	2 AWG	2 AWG	2 AWG	2 AWG	2 AWG	2 AWG	2 AWG	2 AWG	2 AWG	1/0 AWG	1/0 AWG	2/0 AWG	4/0 AWG	4/0 AWG
	2 AWG	2 AWG	2 AWG	2 AWG	2 AWG	2 AWG	2 AWG	2 AWG	2 AWG	2 AWG	2 AWG	1/0 AWG	1/0 AWG	2/0 AWG	4/0 AWG	4/0 AWG
	2 AWG	2 AWG	2 AWG	2 AWG	2 AWG	2 AWG	2 AWG	2 AWG	2 AWG	2 AWG	2 AWG	1/0 AWG	1/0 AWG	2/0 AWG	4/0 AWG	4/0 AWG
	2 AWG	2 AWG	2 AWG	2 AWG	2 AWG	2 AWG	2 AWG	2 AWG	2 AWG	2 AWG	2 AWG	1/0 AWG	1/0 AWG	2/0 AWG	4/0 AWG	4/0 AWG
	2 AWG	2 AWG	2 AWG	2 AWG	2 AWG	2 AWG	2 AWG	2 AWG	2 AWG	2 AWG	2 AWG	1/0 AWG	1/0 AWG	2/0 AWG	4/0 AWG	4/0 AWG
	2 AWG	2 AWG	2 AWG	2 AWG	2 AWG	2 AWG	2 AWG	2 AWG	2 AWG	2 AWG	2 AWG	1/0 AWG	1/0 AWG	2/0 AWG	4/0 AWG	4/0 AWG
	2 AWG	2 AWG	2 AWG	2 AWG	2 AWG	2 AWG	2 AWG	2 AWG	2 AWG	2 AWG	2 AWG	1/0 AWG	1/0 AWG	2/0 AWG	4/0 AWG	4/0 AWG
	2 AWG	2 AWG	2 AWG	2 AWG	2 AWG	2 AWG	2 AWG	2 AWG	2 AWG	2 AWG	2 AWG	1/0 AWG	1/0 AWG	2/0 AWG	4/0 AWG	4/0 AWG
	2 AWG	2 AWG	2 AWG	2 AWG	2 AWG	2 AWG	2 AWG	2 AWG	2 AWG	2 AWG	2 AWG	1/0 AWG	1/0 AWG	2/0 AWG	4/0 AWG	4/0 AWG
	2 AWG	2 AWG	2 AWG	2 AWG	2 AWG	2 AWG	2 AWG	2 AWG	2 AWG	2 AWG	2 AWG	1/0 AWG	1/0 AWG	2/0 AWG	4/0 AWG	4/0 AWG
	2 AWG	2 AWG	2 AWG	2 AWG	2 AWG	2 AWG	2 AWG	2 AWG	2 AWG	2 AWG	2 AWG	1/0 AWG	1/0 AWG	2/0 AWG	4/0 AWG	4/0 AWG
	2 AWG	2 AWG	2 AWG	2 AWG	2 AWG	2 AWG	2 AWG	2 AWG	2 AWG	2 AWG	2 AWG	1/0 AWG	1/0 AWG	2/0 AWG	4/0 AWG	4/0 AWG
	2 AWG	2 AWG	2 AWG	2 AWG	2 AWG	2 AWG	2 AWG	2 AWG	2 AWG	2 AWG	2 AWG	1/0 AWG	1/0 AWG	2/0 AWG	4/0 AWG	4/0 AWG
	2 AWG	2 AWG	2 AWG	2 AWG	2 AWG	2 AWG	2 AWG	2 AWG	2 AWG	2 AWG	2 AWG	1/0 AWG	1/0 AWG	2/0 AWG	4/0 AWG	4/0 AWG
	2 AWG	2 AWG	2 AWG	2 AWG	2 AWG	2 AWG	2 AWG	2 AWG	2 AWG	2 AWG	2 AWG	1/0 AWG	1/0 AWG	2/0 AWG	4/0 AWG	4/0 AWG
	2 AWG	2 AWG	2 AWG	2 AWG	2 AWG	2 AWG	2 AWG	2 AWG	2 AWG	2 AWG	2 AWG	1/0 AWG	1/0 AWG	2/0 AWG	4/0 AWG	4/0 AWG
	2 AWG	2 AWG	2 AWG	2 AWG	2 AWG	2 AWG	2 AWG	2 AWG	2 AWG	2 AWG	2 AWG	1/0 AWG	1/0 AWG	2/0 AWG	4/0 AWG	4/0 AWG
	2 AWG	2 AWG	2 AWG	2 AWG	2 AWG	2 AWG	2 AWG	2 AWG	2 AWG	2 AWG	2 AWG	1/0 AWG	1/0 AWG	2/0 AWG	4/0 AWG	4/0 AWG
	2 AWG	2 AWG	2 AWG	2 AWG	2 AWG	2 AWG	2 AWG	2 AWG	2 AWG	2 AWG	2 AWG	1/0 AWG	1/0 AWG	2/0 AWG	4/0 AWG	4/0 AWG
	2 AWG	2 AWG	2 AWG	2 AWG	2 AWG	2 AWG	2 AWG	2 AWG	2 AWG	2 AWG	2 AWG	1/0 AWG	1/0 AWG	2/0 AWG	4/0 AWG	4/0 AWG
	2 AWG	2 AWG	2 AWG	2 AWG	2 AWG	2 AWG	2 AWG	2 AWG	2 AWG	2 AWG	2 AWG	1/0 AWG	1/0 AWG	2/0 AWG	4/0 AWG	4/0 AWG
	2 AWG	2 AWG	2 AWG	2 AWG	2 AWG	2 AWG	2 AWG	2 AWG	2 AWG	2 AWG	2 AWG	1/0 AWG	1/0 AWG	2/0 AWG	4/0 AWG	4/0 AWG
	2 AWG	2 AWG	2 AWG	2 AWG	2 AWG	2 AWG	2 AWG	2 AWG	2 AWG	2 AWG	2 AWG	1/0 AWG	1/0 AWG	2/0 AWG	4/0 AWG	4/0 AWG
	2 AWG	2 AWG	2 AWG	2 AWG	2 AWG	2 AWG	2 AWG	2 AWG	2 AWG	2 AWG	2 AWG	1/0 AWG	1/0 AWG	2/0 AWG	4/0 AWG	4/0 AWG
	2 AWG	2 AWG	2 AWG	2 AWG	2 AWG	2 AWG	2 AWG	2 AWG	2 AWG	2 AWG	2 AWG	1/0 AWG	1/0 AWG	2/0 AWG	4/0 AWG	4/0 AWG

How to Properly Store Batteries

We recommend bringing the batteries to a 100% state of charge. Then, disconnect the battery from any loads by removing the negative cable from one battery. On average, the batteries lose approximately 2-3% capacity per month. This is subject to increasing if stored in extreme environmental conditions.

How to Maintain the Batteries

12/100Ah/12V230Ah Batteries require very little maintenance. If your batteries are in parallel, just make sure the batteries are charged to 14.2V – 14.6V frequently for internal balance. Our BMS has a built-in passive balancing system that will take care of this for you.

How to Properly Recycle and Dispose of the Batteries

Here at Li-Cube our goal is to provide our customers with long lasting green energy that will support them for years on all their adventures. That is why we not only build batteries that can keep up with you for a long time but also provide industry leading customer support to help you get the most out of your batteries. When the time does come, and your batteries have reached the end of their lifetime it is important to recycle them responsibly.

Here are a few suggestions:

Make sure all loads are removed from your system before removing the batteries.

Warranty

With in five years, if damaged due to the following reasons, it can be replaced or repaired free of charge:

The replacement of defective battery packs is the responsibility of our company, and the user must give our company time to handle any abnormalities.

1. According to the manual, there is an abnormality in the battery pack during normal installation
2. Upon receiving the product, it was found that the appearance was damaged.
3. Under normal operation, there is an abnormality in the battery pack.

Exemption from Liability

1. The voltage level of the device used by the user must meet the voltage range output by the battery pack. If the device is damaged or the battery pack is abnormal due to mismatched specifications or ranges, or even if a fire or explosion occurs, the user shall bear the consequences themselves.

2. The voltage level of the device used by the user must meet the current range output by the battery pack. If the device is damaged or the battery pack is abnormal due to mismatched specifications or ranges, or even if a fire or explosion occurs, the user shall bear the consequences themselves.
3. Do not tear off the product anti-counterfeiting label, otherwise the product is not allowed to be repaired.
4. The product has exceeded the free warranty period.
5. The usage environment is extremely harsh, exceeding the specified environment of the product.
6. If the equipment is damaged or the battery pack is abnormal due to unauthorized replacement or modification of our company's APP or operating software using non-standard materials, our company will not accept any compensation or handling.
7. Damage caused by abnormal natural environment.

Specifications/12V-100AH

Performance Specifications :	
Nominal Voltage	12.8V
Rate Capacity	100Ah
Stored Energy	1280Wh
Cycle Life (@DOD 80%)	6000 Cycle
Approximate Weight	22lbs
Internal Resistance	5mΩ
Max Discharge Current	100A
Max Charge Current	100A
Charging Voltage	14.4Vdc
Cut-off Voltage	10V
Operating Temperature Range	6 in series or 6 in parallel
Charge	-4 ℉ ~ 131 ℉
Discharge	-40 ℉ ~ 131 ℉
Recommended	59 ℉ (15 C) ~ 95 ℉ (35 C)
Self-Discharge Rate	≅ 3%/month
Long Term Storage	Charge every 6 months or as soon as OCV is 12.8V
Power Sonic Chargers	Contact us for information on a suitable charge
Life Expectancy (years)	5 years
Short Circuit Protection	Automatically recover after removal of short
Dimensional Tolerances	L10.4x7.7x8.2in (264x197x208mm)
Terminal Type	M8

Specifications/12V-230AH

Performance Specifications :	
Nominal Voltage	12.8V
Rate Capacity	230Ah
Stored Energy	2944Wh
Cycle Life (@DOD 80%)	6000 Cycle
Approximate Weight	48.5lbs
Internal Resistance	5mΩ
Max Discharge Current	200A
Max Charge Current	600A @ 0.1S
Charging Voltage	14.4Vdc
Cut-off Voltage	10V
Operating Temperature Range	6 in series or 6 in parallel
Charge	-4 F ~ 131 F
Discharge	-40 F ~ 131 F
Recommended	59 F (15 C) ~ 95 F (35 C)
Self-Discharge Rate	≤3%/month
Long Term Storage	Charge every 6 months or as soon as OCV is 12.8V
Power Sonic Chargers	Contact us for information on a suitable charge
Life Expectancy (years)	5 years
Short Circuit Protection	Automatically recover after removal of short
Dimensional Tolerances	L12.6x10.1x9.4 in (320x257x240mm)
Terminal Type	M8

